



PROVEN & TRUSTED SINCE 1952

Project Name/No: _____ Item No: _____

Quantity: _____ SIS#: _____ AIA/CSI#: _____

Portable Waste Oil Caddy Model GOC



The **GILES Portable Waste Oil Caddy** provides food service operators a convenient means to safely remove & contain waste cooking oil for transporting it to an appropriate disposal or recycle collection point within the establishment.

- Has capacity for up to **80 lbs.** of waste oil ... approximately two (2) mid-size fryers.or
- Manual rotary pump ... no hassle with power cords or finding nearby electrical outlets.
- Pump draws waste oil from the tank & discharges it via an attached wand hose into an appropriate bulk recycle collection or disposal container ... to ensure pump performance, waste oil must be filtered, clean & warm.
- Durable stainless steel construction ... fully welded tank.
- Large 8" wheels ... maneuvering & handling is easy; even when full.

Portable & efficient to save you time & money. The perfect solution for safely handling waste cooking oil.

Design Features:



A Sight Glass provides easy-to-see indication that the oil is approaching the full level as waste is received from a fryer ... helps preventing over-filling & spillage.

Capacity:

Volume for waste oil from two (2) medium size fryers (approx. 80 lbs).

Hinged Lid w/Latch:

Holes in lid have rubber grommets to provide receptacles to hold the fryer Discharge Hose Wand while pumping waste into tank.

Also, holds the GOC Hose Wand after emptying is complete, allowing it to drain back into tank rather than drip onto the floor.



GILES Food Service Equipment ▪ ISO 9001 Registered

PO Box 210247; 2750 Gunter Park Drive W; Montgomery, AL 36109 USA

334.272.1457 ▪ Fax 334.239.4117 ▪ Toll Free 800.554.4537 (US/Canada Only) ▪ www.gfse.com ▪ Email: services@gfse.com

Printed in USA, Form 65776 (Rel.Date: Apr.2003) Rev: Sep.2010, Rev. C

Portable Waste Oil Caddy

GOC

Project Name/No: _____ Item No: _____

Quantity: _____ SIS#: _____ AIA/CSI#: _____

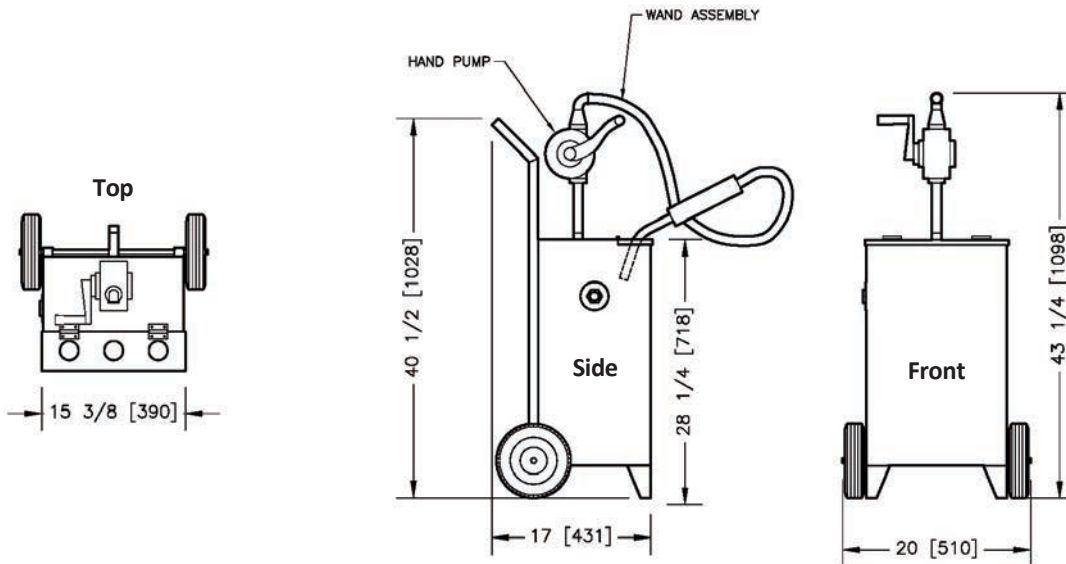

Inches [mm]

Specifications

Construction: Tank - 16 & 18 ga. welded stainless steel ... Handle - 16 ga. 1" sq. stainless steel tube

Dimensions:

Width	Depth	Height	Floor Space
20" [508 mm]	17" [432 mm]	43-1/4" [1099 mm]	2.4 sq.ft [0.2 sq.m]

Operating Temperature:

Max. Temp = 350°F [177°C]

Min. Temp = 100°F [38°C] to 200°F [93°C]

(Designed to handle ONLY warm filtered clean oil)

Capacity:

Holds up to 80 lbs [36 kg] of waste cooking oil.

Shipping Specifications:

Width	Depth	Height	Cube	Crated Weight
21" [534 mm]	18" [457 mm]	46" [1169 mm]	10 cu ft [0.3 cu m]	67 lbs [137 kg]

How To Specify

1. Ordering Options

Specify part number from the following:

✓	Model	Item Number
	GOC	79187

2. Shipping

Specify preferred shipping method

Typically ships via Parcel Service.



2750 Gunter Park Drive West • Montgomery, AL 36109 USA
334.272.1457 • Toll Free: 800.554.4537

Product specifications and/or designs are subject to changes without notice. Such revisions do not entitle the buyer to corresponding changes, improvements, additions or replacements for previously purchased equipment.