



Project Name/No: \_\_\_\_\_ Item No: \_\_\_\_\_  
 Quantity: \_\_\_\_\_ SIS#: \_\_\_\_\_ AIA/CSI#: \_\_\_\_\_

# Open Vat Electric Fryer Model GBF-35 / GBF-50



CE 380-415V ONLY

Banked battery of up to 3 wells available.



Small footprint, multi-purpose fryer cooks a wide variety of menu items quickly & easily. Rapid temperature recovery can help boost productivity, enabling this compact unit to handle those unexpected heavy sales periods with ease.

- 14" square fry vat ... choose **35 lb.** or **50 lb.** shortening capacity ... *GBF-50* model has a deep cool zone to help minimize crumb carbonization, ideal for fresh breaded products ... lower oil volume of the *GBF-35* model can lower your operating costs .. perfect for french fries.
- 18,000W/3-ph, 10,000W/3-ph or 10,000W/1-ph ... all have plenty of cooking power.
- Compact cabinet design ... single unit is only 16" wide (approx.).
- Can be ordered as a 2 or 3-well banked fryer battery.
- Intuitive computer controller ... accurately regulates cooking time & temperature, dual timers, programmable cook presets for up to 50 menu items, monitors fryer operation, displays instructional & alarm info ... features **COOL Mode**, **FORCE FILTER** control, **LOW OIL** detection, **BOIL-OUT** program, password security control & multi-language selections.
- **On-board Oil Filtration** system helps minimize the task of filtering oil. Features a robust 1/2 hp pump. Centralized system serves all vats in a banked system. Sustainable, stainless steel, *Filter Screen* is provided as standard ... eliminates filter paper, helping reduce cost of operation.
- Durable stainless steel construction for long life and easy cleaning.
- Durable 5" casters provide easy portability ... front locking brakes.
- **Available Options:**
  - ◊ **Oil level top-off system** ... fresh oil supplied from an on-board saddle tank (or from a customer-provided bulk fresh oil supply).
  - ◊ **Direct connection** for bulk oil management systems (fresh supply and/or waste).
  - ◊ **Auto-Basket Lifts** ... automatically lowers & raises cooking baskets into & out of vat at beginning & end of cook cycle. *Manual basket hanger rack is standard.*
  - ◊ *Optional Giles KITCHENTRAC®* remote monitoring capability is available for the GBF.

## Standard Features:

**On-Board Oil Filtration System:** Robust 1/2 hp



pump, designed to complete a filter cycle in 5 mins. Filters oil through a sustainable, stainless steel mesh, filter screen (or filter paper). One-step drain, crumb flush & filtering. One turn of a valve refills vat with filtered reconditioned oil.

Proper use can increase oil life by as much as 50%.

- **2-Year Parts & Labor Warranty**
- Built-in oil filtration system, 1/2 hp pump
- Computer Controller
- Oil temperature high-limit shutdown
- Drain valve safety interlock
- Low oil level detection
- High element temp safety control
- Durable 5" Casters - front locking wheels
- Heat-resistant Brush Set
- Product Stirring Utensil
- Waste Oil Discharge Hose
- Metal Crumb Scoop
- Sustainable, stainless steel, oil filter screen

## Optional Features:

### Auto-Basket Lift Option:



Load, set and start cook cycle in one step. Basket automatically lowers when started and raises when done cooking, lifting cooked product from the hot cooking oil ... no more over-cooking. Dumping cooked product is safe and easy. Lifts can be disabled if desired.

### Oil Level Top-Off



Each cook cycle reduces oil volume in the vat which must be replenished routinely to ensure satisfactory performance. This option makes the task efficient & easy. Fresh oil is stored in a **Saddle Tank**, hanging on cabinet side. A fryer with a bulk oil option can receive fresh oil from a bulk oil supply. When controller signals low oil level, a top-off pump is operator activated with a single control panel switch.



### Remote monitoring with Optional Giles' KITCHENTRAC® ...

provides a unique opportunity using WiFi connectivity to monitor equipment in real time and collect critical data across multiple locations. Your cooking equipment will seamlessly communicate with the KitchenTrac server and allow easy access to the critical data you need to manage effectively. [CLICK here for details](#) ... **service fees required for use.**

### Bulk Oil Option - Direct Connection

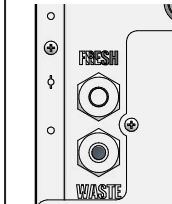

Optional internal fryer plumbing provides capability for easy direct connection to a customer-provided bulk oil management system. Efficiently fill or top-off vat with fresh oil and/or dispose of waste oil using a bulk system. **Either, fresh oil or waste oil, is available as a separate option.**

**GILES Food Service Equipment** ▪ ISO 9001 Registered

PO Box 210247; 2750 Gunter Park Drive W; Montgomery, AL 36109 USA

334.272.1457 ▪ Fax 334.239.4117 ▪ Toll Free 800.554.4537 (US/Canada Only) ▪ [www.gfse.com](http://www.gfse.com) ▪ Email: [services@gfse.com](mailto:services@gfse.com)

Printed in USA, 65684 (Rel. Date: Jan.2011, Rev. Date: Dec.2022, Rev. K)

# Open Vat Electric Fryer

## Model GBF-35 & GBF-50

Project Name/No: \_\_\_\_\_ Item No: \_\_\_\_\_

Quantity: \_\_\_\_\_ SIS#: \_\_\_\_\_ AIA/CSI#: \_\_\_\_\_

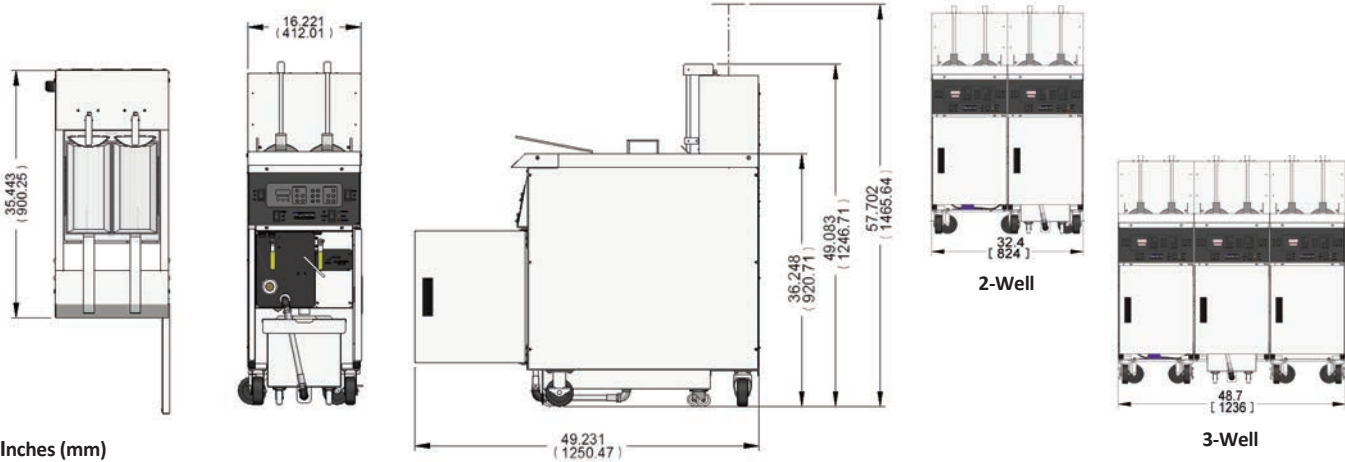

**Construction:** 16 to 20 ga. 430-series stainless steel; stainless steel tubular frame; (2) stainless Firebar heating elements

Electrical Specifications:				
Volts	Ph	Hz	kW [per Vat]	Amps [per Vat]
208	1	60	10	50
	3	60	10	28
	3	60	18	51
240	1	60	10	43
	3	60	10	24
	3	60	18	44
380-415	3	50	15 - 18.6	26 - 28

Dimensions:				
Config.	Width	Height	Depth	Floor Space
Single	16.2 in (412 mm)	49.1 in (1247 mm)	35.4 in (900 mm)	4.0 sq ft (0.37 sq m)
2-Bank	32.4 in (824 mm)	49.1 in (1247 mm)	35.4 in (900 mm)	8.0 sq ft (0.74 sq m)
3-Bank	48.7 in (1236 mm)	49.1 in (1247 mm)	35.4 in (900 mm)	12.0 sq ft (1.11 sq m)

- Power output will vary according to input power
- Service cords **NOT** included
- Each unit in a banked system requires separate power supply

Capacities [per Vat]:			
Model	Oil	Fries [total]	Chicken mixed pieces [total]
GBF-35	35 lbs [15.9 kg]	5 lbs [2.3 kg]	7 lbs (8-way cut, 3-1/3 lb bird)
GBF-50	50 lbs [22.6 kg]	5 lbs [2.3 kg]	12 lbs (8-way cut, 3-1/3 lb bird)

Shipping Specifications:			
Config.	Crated Wt	Crated Dimensions	Cube
Single	385 lb (175 kg)	35"W x 45"L x 60"H [889 mm x 1143 mm x 1524 mm]	55 cu ft (1.6 cu m)
2-Bank	565 lb (256 kg)	51"W x 45"L x 60"H [1295 mm x 1143 mm x 1524 mm]	80 cu ft (2.3 cu m)
3-Bank	768 lb (348 kg)	67"W x 45"L x 60"H [1651 mm x 1143 mm x 1524 mm]	105 cu ft (3.0 cu m)

**Vat Size:** 14 x 16-1/4"

**Basket Size:** 6-1/2" [W] x 13-1/4" [L] x 6" [D]

**Computer Controller (each fryer):**

Cooking temperature adjustable to **max. 350°F [177°C]**

Dual basket timer, (50) programmable cooking presets, **COOL Mode**, **FORCE FILTER** control, **LOW OIL** detection, **BOIL-OUT** program, password security, multiple language selections, max. element temp safety.

High-Limit Oil Temperature Safety Shutdown = **450°F [232°C]**

**Accessory Items Included:** (2) fry baskets ea. vat • (1) Crumb Screen ea. vat • Round-bristle drain brush • Utility/pot brush • Round-bristle L-shape brush • Stirring utensil • Crumb scoop • Waste oil discharge hose

Product specifications and/or designs are subject to change without notice. Such revisions do not entitle the purchaser to corresponding changes, improvements, additions or replacements for previously purchased equipment.



2750 Gunter Park Drive West • Montgomery, AL 36109 USA  
334.272.1457 • Toll Free: 800.554.4537

# Open Vat Electric Fryer Model GBF-35 & GBF-50

Project Name/No: \_\_\_\_\_ Item No: \_\_\_\_\_

Quantity: \_\_\_\_\_ SIS#: \_\_\_\_\_ AIA/CSI#: \_\_\_\_\_

## How To Specify

### 1 Electrical Option : Choose Applicable Item Number

✓	Model	Volt	Phase	Hz	kW	Item Number	*w/WIFI Option	
	GBF-35	208	3	60	18	71562	71562W	
			3	60	10	72009	72009W	
			1	60	10	72010	72010W	
		240	3	60	18	71563	71563W	
			3	60	10	72011	72011W	
			1	60	10	72012	72012W	
		380-415	3	50	15-18.6	71568	71568W	
	GBF-50	208	3	60	18	71558	71558W	
			3	60	10	71986	71986W	
			1	60	10	71930	71930W	
		240	3	60	18	71559	71559W	
			3	60	10	71987	71987W	
			1	60	10	71931	71931W	
			380-415	3	50	15-18.6	71566	71566W

### 2 Select Configuration + Lift Option: Choose as indicated

✓	Option	Select Configuration + Lift Option	
	Single	1	Choose configuration
	Banked	2 3	
	Basket Lifts	0 1 2 3	Choose # units w/lifts

Build part no. = XXXXXX-[1,2,3] config + [0,1,2,3] lift option  
 71558-10 = single, 208V/3ph, 18kW, no basket lifts  
 71930-22 = 2-bank, 208V/3ph, 10kW, basket lifts both wells  
 71931W-11 = single, 240V/1ph, w/KitchenTrac + basket lifts

When mix of "lift & no lift" is specified on a banked system, unit(s) with lifts will be oriented from the left side. Units without basket lifts have standard hanger rack.

\* Units ordered with KITCHENTRAC® WiFi option require a small monthly server hosting fee for the service. Each controller unit on a banked system requires separate fee.

### 3 Choose Oil Plumbing Option: Make selections as indicated

✓	Option	Code	
	Add Oil Top-Off	T*	Vat top-off system w/saddle tank fresh oil supply
	Bulk Fresh Oil	B	Bulk fresh oil supply system connection
	Bulk Waste Oil	W	Bulk waste oil handling system connection

\* Option [T] is not compatible with option [B]

### 4 Create Item Number w/Options:

Append your option code selections to the base item number created in step #2, as shown below:

71558-11 = Std plumbing, no option  
 71558W-11-W = Bulk waste oil option  
 71930-10-TW = Add oil topoff + bulk waste oil option  
 71558-11-B = Bulk fresh oil supply option

*If needed, call factory for more information or assistance in specifying your appliance choice*

### 5 Additional Accessories & Supplies (sold separately) \* provided w/fryer

✓	Qty	Item Description	Item Number	✓	Qty	Item Description	Item Number
		*Fry Basket, 13-1/4 x 6-1/2 x 6	*41040			Boil Out (case of 24 -6 oz packet)	72003
		*Crumb Screen/Basket Support	*41041			*Utility Brush	*71100
		*Stainless, Mesh Filter Screen	*41078			*Round-bristle Straight Drain Brush	*71025
		Fry Pot Cover	93362			*Round-bristle L-Tipped Brush	*93609
		Filter Paper (case of 100 sheets)	65871			Filter Pan Insert, Crumb Catcher	99550
		Filter Powder (case of 60 - 5 oz packets)	72004				

### 6 Shipping: Specify shipping method

Product specifications and/or designs are subject to change without notice. Such revisions do not entitle the purchaser to corresponding changes, improvements, additions or replacements for previously purchased equipment.