



PROVEN & TRUSTED SINCE 1952

Project Name/No: \_\_\_\_\_ Item No: \_\_\_\_\_

Quantity: \_\_\_\_\_ SIS#: \_\_\_\_\_ AIA/CSI#: \_\_\_\_\_

# Multi-Appliance Ventless Recirculating Hood

## FSH-4



2 Configuration Options:  
Ceiling Suspended  
or  
72" Floor-Stand



- 48" wide, Type-1, Ventless Recirculating Hood for **electric** fryers, griddles, broilers, ranges & ovens.
- Free-standing on 72" tall floor stand to maximize usable hood width (*standard*) -**or-** ceiling suspended w/side skirts (*optional*).
- No venting to outside required ... generally, can be installed where conventional ventilation hood solutions are prohibited or too costly for the budget ... vented solutions should always be the first alternatives.
- Durable stainless steel construction.
- Proven 4-stage air cleaning technology meets requirements for grease-laden vapor removal for a variety of commercial cooking appliances. Listed to **UL-YZCT (-7 Canada), complies with ANSI/UL-710B.**
- Listed for the **Ansul® R102 Wet Chemical Fire Suppression System.** Hood is factory pre-plumbed, with piping, plenum nozzles, detector link brackets & cable conduit stubbed out ready for connection. Does not include appliance drop-down nozzles. Customer supplies system, field installation, final set-up & commissioning ... must be supplied & installed by an authorized Ansul® service company (not included with purchase).

### Design Features

#### Ventless Hood System 4-Stage Air Cleaning:

- [1] Two (2) stainless steel Baffle Filters (*not seen*) trap large grease particulate.
- [2] Two (2) disposable pre-filters trap smaller particulate & help remove moisture.
- [3] Two (2) renewable Electronic Air Cleaner (EAC) collector cells electrostatically capture & collect fine particulate on collection fins.
- [4] Two (2) disposable charcoal filters help to control cooking aromas in the exhausted air.

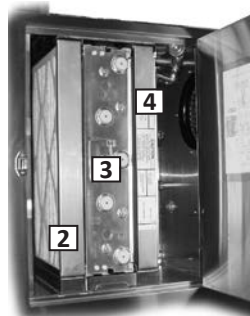

#### Standard Features:

- Built-in appliance interlock relay.
- **PUSH-TO-START** power switch ... must be pressed after power interruptions to restart hood & provide power to cooking appliances underneath ... required by code in some jurisdictions.
- Complete filter set included.
- Choose 72" tall full-skirt floor stand configuration.
- Built-in filter cleaning timer feature ... helps user maintain optimum hood performance.

### Limitations: HOOD APPROVED ONLY FOR USE WITH ELECTRICALLY HEATED APPLIANCES ... NO GAS

Equipment Type	Max. Input Power (kW)	Max. Cooking Temperature	Max. Shortening Capacity	Max. Cooking Area
Fryers	40 (Total) or 20 (per Fryer)	350°F [177°C]	160 lbs [72 kg] [Total] 80 lbs [36 kg] [per Fryer]	576 sq in[0.37 sq m] single fryer, 760 sq in[0.37 sq m] any combination
Ovens	55	500°F [260°C]	N/A	45"[1143mm] W x 42"[1067mm] D
Griddles	25	400°F [204°C]	N/A	45"[1143mm] W x 26"[660mm] D
Ranges	25	400°F [204°C]	N/A	45"[1143mm] W x 26"[660mm] D
Broilers (Vert/Horiz)	25	500°F [260°C]	N/A	45"[1143mm] W x 26"[660mm] D 42"[1067mm] max (appl top to hood btm)

#### IMPORTANT INFORMATION !

Orders for GILES Recirculating/Ventless Hood systems will not be accepted until Giles verifies ... 1). the Purchaser has received all necessary approvals from local authorities ... 2). the cooking appliances to be used are within the hood's listing limitations ... 3). the Purchaser is aware of specific requirements & limitations with which installation must comply, as stated in the **GFSE Recirculating/Ventless Hood Approval Letter (HAL)**. The **Approval Letter** must be fully completed & submitted, along with any other requested information, and must be approved by Giles Technical Services personnel before an order will be accepted.

The HAL document is available for review & download by clicking here:

[HOOD APPROVAL LETTER](#)

**GILES Food Service Equipment** • ISO 9001-2015 Registered

PO Box 210247; 2750 Gunter Park Drive W; Montgomery, AL 36109 USA

334.272.1457 • Fax 334.239.4117 • Toll Free 800.554.4537 (US/Canada Only) • [www.gfse.com](http://www.gfse.com) • Email: [services@gfse.com](mailto:services@gfse.com)

Printed in USA, Form 65574 (Rel. Date: Feb.2013; Rev. Date: Aug.2022, Rev. K

# Ventless Hood

## Model FSH-4

Project Name/No: \_\_\_\_\_ Item No: \_\_\_\_\_

Quantity: \_\_\_\_\_ SIS#: \_\_\_\_\_ AIA/CSI#: \_\_\_\_\_

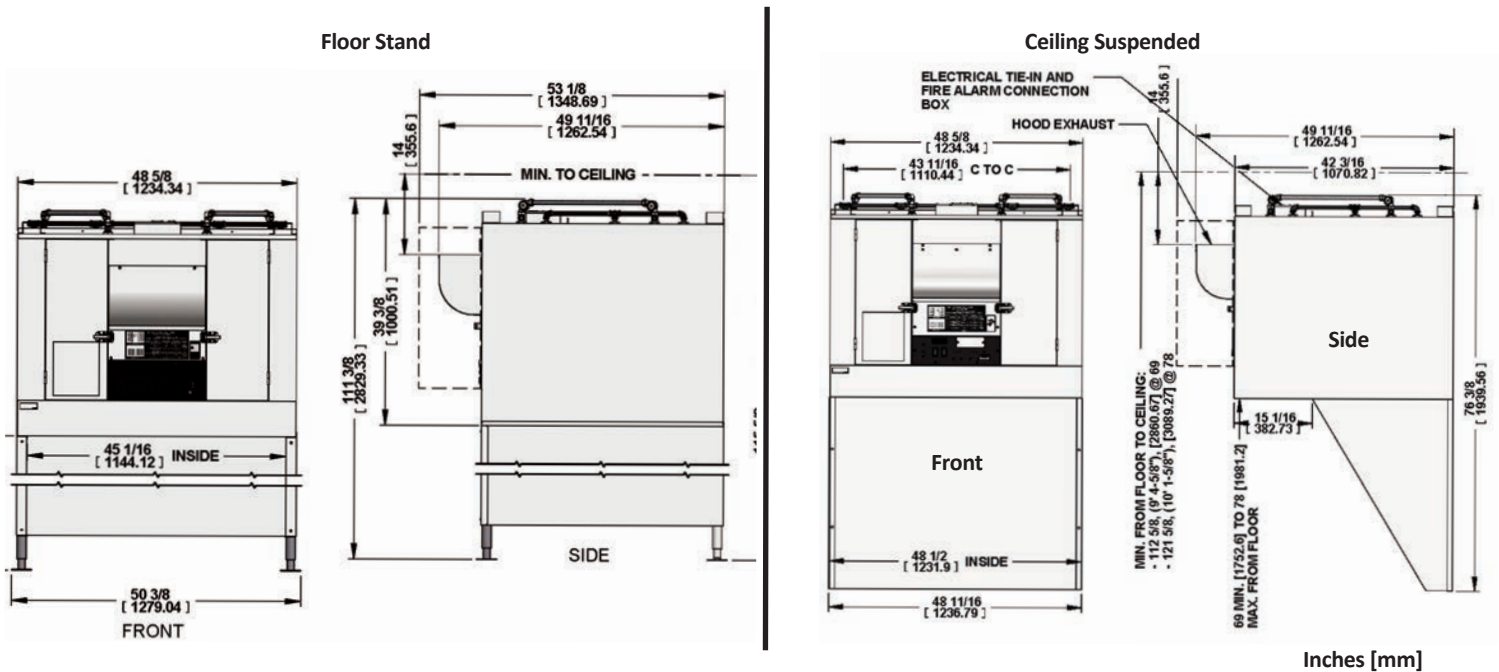

### Specifications

**Construction:** 18 & 20-Ga high-grade stainless steel sheet metal ... formed & welded

Dimensions: * Includes Side Skirts				Electrical Specifications: Hood Only			
Width	Depth	Height		Voltage	Hz	Phase	Amps
		Suspended	Floor Stand				
48-5/8" [1234 mm]	49-11/16" [1263 mm]	*76-5/16" [1938 mm]	111-3/8" [2829 mm]	208-240	60	1	8
				<ul style="list-style-type: none"> <li>Power cord NOT provided; field wiring required.</li> <li>Neutral line required for lights.</li> </ul>			

#### Mechanical Specifications:

Hood Exhaust - 840 to 940 CFM
Sound Level (approx) - 75 dB
Min. Exhaust Clearance - 14" [336 mm] (top of duct to ceiling)

#### Shipping Specifications:

Crated Wt:	Suspended:	645 lbs [293 kg]
	Floor Stand:	835 lbs [378 kg]
Cube: 56"[1422mm x x86"[2184mm] x 53"[1346mm]=147.7 cu ft [4.2 cu m]		

**Accessory Items Included:** (2) Baffle Filters • (2) Pre-Filters • (2) EAC Collector Cells • (2) Charcoal Filters • (1) Tube Sealing Silicone • (1) Can, Spray Foam EAC Cell Cleaner (sample)

### IMPORTANT! Before Ordering

- Purchaser must obtain, read, complete & submit a [Giles Hood Approval Letter \(HAL\)](#). By signing a HAL, the purchaser affirms that installation site has been assessed & it is compliant with the minimum requirements, stated therein, regarding kitchen size, ceiling height, fresh outside air supply, room air exchange rate, exhaust ventilation, clearances, etc.
- Verify that cooking appliances to be used are within limitations shown in the table on first page ... contact factory to resolve any questions.
- Does available electrical power meet hood specifications?

### How To Specify

#### 1 Determine Hood Item Number:

✓	Voltage	Hz	Ph	Configuration	Item Number
	208-240	60	1	72" Stand (Standard)	71477
	208-240	60	1	Ceiling Suspended (Optional)	71478

#### 2 Extra Accessories (sold separately) Specify quantity:

✓	Qty	Description	Part Number
		Pre-Filter	91707
		EAC Filter (Left-side)	20521
		EAC Filter (Right-side)	20520
		Charcoal Filter	30248
		EAC Foaming Spray Cleaner (12-ct Case, 20-oz can)	41510